

THE ESPLANADE REHABILITATION

ASPHALT PATCHING AND OVERLAY

NOTES

GENERAL

- G1. ALL WORKS TO BE CARRIED OUT IN ACCORDANCE WITH THE CURRENT STANDARD DRAWINGS AND SPECIFICATIONS OF THE SURFCOAST SHIRE COUNCIL.
- G2. DO NOT SCALE DRAWINGS - USE ONLY DIMENSIONS PROVIDED ON PLANS
- G3. ALL DIMENSIONS ARE IN METRES (m) UNLESS OTHERWISE STATED.
- G4. ALL LEVELS ARE TO AUSTRALIAN HEIGHT DATUM (A.H.D.) IN METRES (m) UNLESS OTHERWISE STATED
- G5. EXISTING DRAINAGE AND UNDERGROUND SERVICES ARE TO BE LOCATED PRIOR TO THE COMMENCEMENT OF WORKS AND RELEVANT AUTHORITIES NOTIFIED. FOR SERVICE INFORMATION CONTACT "DIAL BEFORE YOU DIG" ON 1800 819101. ANY DAMAGE AND SUBSEQUENT REPAIRS WILL BE THE RESPONSIBILITY OF THE CONTRACTOR.
- G6. THE CONTRACTOR IS TO ARRANGE FOR THE RELOCATION OF UNDERGROUND SERVICES IF REQUIRED, PRIOR TO THE COMMENCEMENT OF WORKS.
- G7. THE CONTRACTOR SHALL BE RESPONSIBLE FOR ADVISING THE WORKS SUPERINTENDENT AND THE C.F.A. OPERATIONS CENTRE OF THE RELOCATION OR ALTERATION OF ANY FIRE HYDRANTS WITHIN ONE WORKING DAY.
- G8. WHERE THE MANAGEMENT OF TRAFFIC DURING CONSTRUCTION REQUIRES REDUCED SPEED LIMITS, THE CONTRACTOR SHALL BE RESPONSIBLE FOR SUBMITTING A TRAFFIC MANAGEMENT PLAN TO VICROADS, SOUTH WESTERN REGION, AND THE SUPERINTENDENT AND OBTAIN A MEMORANDUM OF CONSENT. THE APPLICATION MUST BE SUBMITTED 14 DAYS PRIOR TO THE INTENDED PLACEMENT OF THE SPEED LIMIT.
- G9. BEFORE THE COMMENCEMENT OF WORKS, THE CONTRACTOR SHALL VERIFY ANY REQUIREMENTS FOR THE INSTALLATION OF NEIGHBOURHOOD CABLING FOR THE EXTENT OF THE WORKS BY CONTACTING THE NEIGHBOURHOOD CABLING OPERATIONS MANAGER ON 03 5339 0500.
- G10. THE CONTRACTOR SHALL GIVE TWO (2) DAYS CLEAR NOTICE OF INTENTION TO COMMENCE WORKS TO THE AFFECTED RESIDENTS AND TO COUNCIL. THE CONTRACTOR IS TO ARRANGE FOR THE INSPECTION OF EXISTING PRIVATE PROPERTY AND THE ROADWAY, WHERE NECESSARY, TO ASSESS EXISTING DAMAGE. THE CONTRACTOR WILL BE LIABLE FOR THE REPAIR OF ANY NEW DAMAGE AS A RESULT OF THESE CONSTRUCTION WORKS.
- G11. ANY DIFFERENCES BETWEEN THE PLANS AND EXISTING CONDITIONS ARE TO BE REPORTED IMMEDIATELY TO THE WORKS SUPERINTENDENT.
- G12. ALL SURPLUS MATERIAL IS THE PROPERTY OF THE CONTRACTOR AND SHALL BE REMOVED AND DISPOSED BY THE

CONTRACTOR TO THE SATISFACTION OF THE WORKS SUPERINTENDENT.

G13. THE CONTRACTOR IS TO CAREFULLY REMOVE AND REINSTATE ANY STREET FURNITURE, SIGNS ETC., AS REQUIRED TO CARRY OUT THE WORKS.

G14. THE CONTRACTOR IS TO REINSTATE THE EXISTING ROADWAY, DRIVEWAYS, FOOTPATHS, KERBS, FENCES ETC., TO COUNCIL STANDARDS AND DETAILS PROVIDED AND TO THE SATISFACTION OF THE WORKS SUPERINTENDENT.

G15. ON THE COMPLETION OF WORKS, THE SITE IS TO BE CLEANED UP TO THE SATISFACTION OF THE WORKS SUPERINTENDENT.

ASPHALT PATCHING & OVERLAY

- A1. ASPHALT OVERLAY SHALL BE 30mm SIZE 10 TYPE H, CLASS C320.
- A2. EXISTING SURFACE SHALL BE EDGE PLANED ALONG KERB LINE PRIOR TO OVERLAY TO ENSURE EXISTING LIP OF KERB LEVEL REMAINS UNCHANGED POST OVERLAY.
- A3. SUITABLE TACK COAT SHALL BE APPLIED PRIOR TO ASPHALT OVERLAY
- A4. PATCHING LOCATIONS ARE NOT SHOWN AT THE PRECISE LOCATION ON THESE PLANS. COUNCIL WILL MARK THESE LOCATIONS ONSITE AS SHOWN ON THE ASPHALT PATCHING PLAN READY FOR THE CONTRACTOR TO CARRY OUT PATCHING.

TRAFFIC MANAGEMENT

- T1. TRAFFIC MANAGEMENT PLAN SHALL ALLOW FOR MINIMUM DISRUPTION TO TRAFFIC WITH CONTRA FLOW PERMITTED FOR LOCALIZED WORKS. WHERE LANE CLOSURE IS REQUIRED, FLOW IN ONE DIRECTION MUST BE MAINTAINED BY EITHER:
 - T1.1 SOUTHBOUND ONLY WITH RIGHT TURN IN AND RIGHT TURN OUT OF SIDE STREETS.
 - T1.2 NORTHBOUND ONLY WITH LEFT TURN IN AND LEFT TURN OUT OF SIDE STREET.

T2. ANY ADDITIONAL TEMPORARY SIGNS SHALL BE THE RESPONSIBILITY OF THE CONTRACTOR TO ERECT.

T3. VMS BOARD SHALL BE PLACED AT BOTH END OF THE WORKS AND SHALL BE RESPONSIBILITY OF THE CONTRACTOR. MESSAGE TO BE APPROVED BY COUNCIL.

LINE MARKING

L1. LINE MARKING IS TO BE COMPLETED ACCORDING TO AS 174.2.10 STANDARD IN WATER BASED LINE MARKING PAINT EXCEPT WHERE NOTED ON PLANS AS LONG LIFE THERMOPLASTIC PAINT.

LEGEND

- ASPHALT OVERLAY
- PATCH DESIGN 1
- PATCH DESIGN 2



WARNING
BEWARE OF UNDERGROUND SERVICES AND OVERHEAD POWERLINES
THE LOCATION OF UNDERGROUND SERVICES SHOWN ARE APPROXIMATE ONLY AND THEIR EXACT POSITION MUST BE PROVEN ON SITE



-		-	-	-
-		-	-	-
-		-	-	-
A	FOR CONSTRUCTION	CY	17-6-19	
No.	ZONE	REVISION	APPROVED	DATE

© SURF COAST SHIRE
THIS DOCUMENT IS COPYRIGHT, NO PART OF IT CAN BE USED, AMENDED OR REPRODUCED BY ANY PROCESS, WITHOUT PERMISSION FROM THE INFRASTRUCTURE MANAGER OF THE SURF COAST SHIRE
SURF COAST SHIRE TORQUAY OFFICES
1 MERRIJIG DRIVE (P.O. BOX 350)
TORQUAY, VICTORIA 3228
PH : (03) 5261 0600 FAX : (03) 5261 0526



NORTH POINT

DESIGNED: CY	DRAWING No.: T19-029
DRAWN: CY	SHEET: 1 of 12
CHECKED: PZ	DATE: JUNE '19
PROJECT ENGINEER: CY	
MANAGER ENGINEERING SERVICES: IS	

THE ESPLANADE, TORQUAY PATCHING AND RESEAL	REV. A
COVER SHEET	A3

LEGEND

 ASPHALT OVERLAY.



WARNING
BEWARE OF UNDERGROUND SERVICES AND OVERHEAD POWERLINES
THE LOCATION OF UNDERGROUND SERVICES SHOWN ARE APPROXIMATE ONLY AND THEIR EXACT POSITION MUST BE PROVEN ON SITE

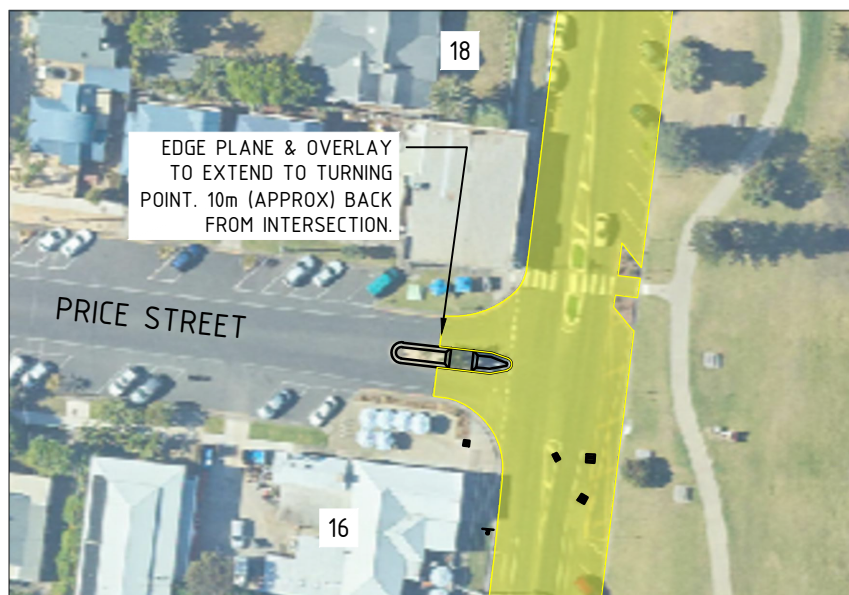

-	-	-	-
-	-	-	-
-	-	-	-
A	FOR CONSTRUCTION	CY	17-6-19
No.	ZONE	REVISION	APPROVED DATE

© SURF COAST SHIRE
THIS DOCUMENT IS COPYRIGHT, NO PART OF IT CAN BE USED, AMENDED OR REPRODUCED BY ANY PROCESS, WITHOUT PERMISSION FROM THE INFRASTRUCTURE MANAGER OF THE SURF COAST SHIRE
SURF COAST SHIRE TORQUAY OFFICES
1 MERRIJIG DRIVE (P.O. BOX 350)
TORQUAY, VICTORIA 3228
PH : (03) 5261 0600 FAX : (03) 5261 0526



NORTH POINT

DESIGNED: CY	DRAWING No.: T19-029
DRAWN: CY	SHEET: 02 OF 12
CHECKED: PZ	DATE: JUNE '19
PROJECT ENGINEER: CY	
MANAGER ENGINEERING SERVICES: IS	

THE ESPLANADE, TORQUAY PATCHING AND RESEAL	REV. A
OVERLAY EXTENTS	A3

PATCH DESIGN 1.

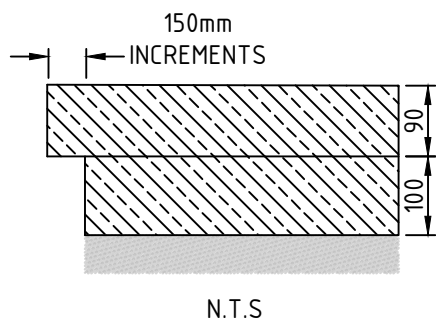

SIZE 20mm TYPE SI, ASPHALT CLASS C320
 SIZE 20mm TYPE SI, ASPHALT CLASS C320
 SUBGRADE TO BE COMPACTED TO 98% STD MDD

LEGEND

PATCH DESIGN 1



WARNING
 BEWARE OF UNDERGROUND SERVICES AND OVERHEAD POWERLINES
 THE LOCATION OF UNDERGROUND SERVICES SHOWN ARE APPROXIMATE ONLY AND THEIR EXACT POSITION MUST BE PROVEN ON SITE



SCALE 1 : 1000 @ A3

-	-	-	-	-
-	-	-	-	-
-	-	-	-	-
A	FOR CONSTRUCTION	CY	17-6-19	
No.	ZONE	REVISION	APPROVED	DATE

© SURF COAST SHIRE
 THIS DOCUMENT IS COPYRIGHT, NO PART OF IT CAN BE USED, AMENDED OR REPRODUCED BY ANY PROCESS, WITHOUT PERMISSION FROM THE INFRASTRUCTURE MANAGER OF THE SURF COAST SHIRE
 SURF COAST SHIRE TORQUAY OFFICES
 1 MERRIJIG DRIVE (P.O. BOX 350)
 TORQUAY, VICTORIA 3228
 PH : (03) 5261 0600 FAX : (03) 5261 0526



NORTH POINT

DESIGNED: CY	DRAWING No.: T19-029
DRAWN: CY	SHEET: 3 of 12
CHECKED: PZ	DATE: JUNE '19
PROJECT ENGINEER: CY	
MANAGER ENGINEERING SERVICES: IS	

THE ESPLANADE, TORQUAY PATCHING AND RESEAL	REV. A
PATCHING LOCATION	A3

PATCH DESIGN 1.

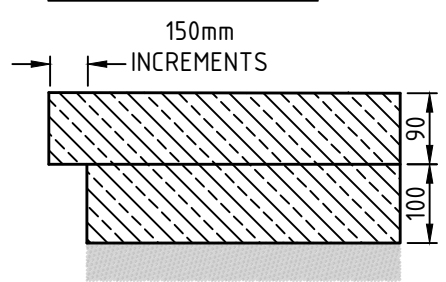

SIZE 20mm TYPE SI, ASPHALT CLASS C320
 SIZE 20mm TYPE SI, ASPHALT CLASS C320
 SUBGRADE TO BE COMPACTED TO 98% STD MDD

N.T.S

PATCH DESIGN 2.

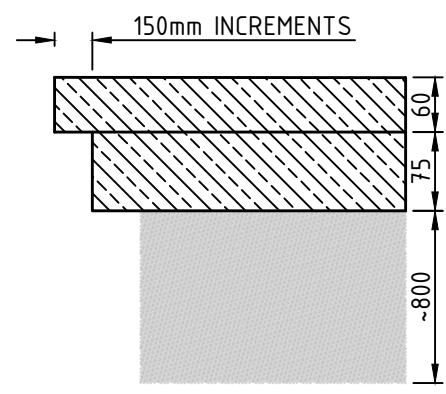

SIZE 20mm TYPE SI, ASPHALT CLASS C320
 SIZE 20mm TYPE SI, ASPHALT CLASS C320
 REMOVE THE FULL DEPTH OF CRUSHED ROCK AND REPLACE EXISTING MATERIAL IN MAX 200mm THICK LAYERS COMPACTED TO 98% MOD MDD

N.T.S



LEGEND

- PATCH DESIGN 1
- PATCH DESIGN 2



WARNING
 BEWARE OF UNDERGROUND SERVICES AND OVERHEAD POWERLINES
 THE LOCATION OF UNDERGROUND SERVICES SHOWN ARE APPROXIMATE ONLY AND THEIR EXACT POSITION MUST BE PROVEN ON SITE

-	-	-	-	-
-	-	-	-	-
-	-	-	-	-
A	FOR CONSTRUCTION	CY	15-7-19	
No.	ZONE	REVISION	APPROVED	DATE

© SURF COAST SHIRE
 THIS DOCUMENT IS COPYRIGHT, NO PART OF IT CAN BE USED, AMENDED OR REPRODUCED BY ANY PROCESS, WITHOUT PERMISSION FROM THE INFRASTRUCTURE MANAGER OF THE SURF COAST SHIRE
 SURF COAST SHIRE TORQUAY OFFICES
 1 MERRIJIG DRIVE (P.O. BOX 350)
 TORQUAY, VICTORIA 3228
 PH : (03) 5261 0600 FAX : (03) 5261 0526



DESIGNED: CY	DRAWING No.: T19-029
DRAWN: CY	SHEET: 4 of 12
CHECKED: PZ	DATE: JUNE '19
PROJECT ENGINEER: CY	
MANAGER ENGINEERING SERVICES: IS	

THE ESPLANADE, TORQUAY PATCHING AND RESEAL		REV. A
PATCHING LOCATION		A3

SCALE 1 : 1000 @ A3

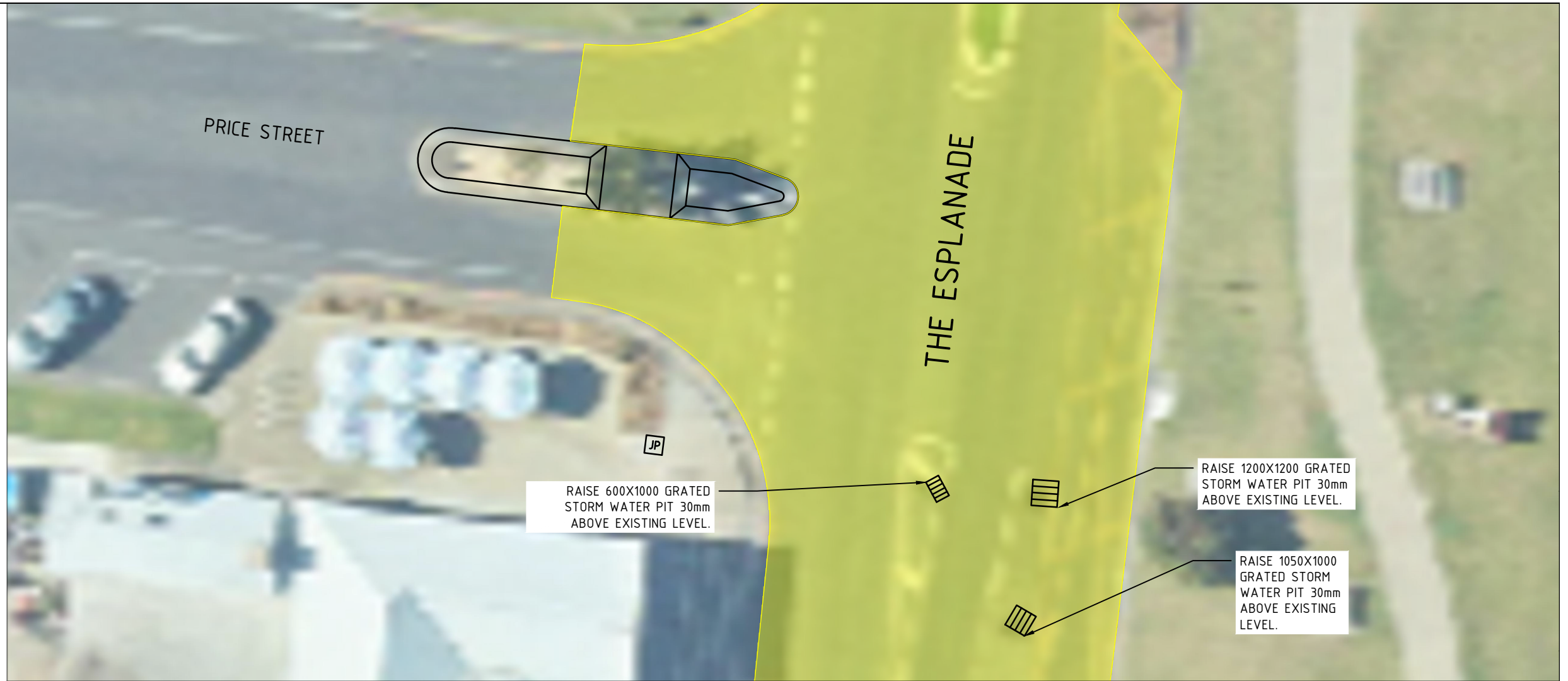



SITE PHOTO

LEGEND

 ASPHALT OVERLAY.



WARNING
BEWARE OF UNDERGROUND SERVICES AND OVERHEAD POWERLINES
THE LOCATION OF UNDERGROUND SERVICES SHOWN ARE APPROXIMATE ONLY AND THEIR EXACT POSITION MUST BE PROVEN ON SITE

-		-	-	-	© SURF COAST SHIRE THIS DOCUMENT IS COPYRIGHT, NO PART OF IT CAN BE USED, AMENDED OR REPRODUCED BY ANY PROCESS, WITHOUT PERMISSION FROM THE INFRASTRUCTURE MANAGER OF THE SURF COAST SHIRE		 NORTH POINT	DESIGNED: CY	DRAWING No.: T19-029	THE ESPLANADE, TORQUAY PATCHING AND RESEAL	REV.
-		-	-	DRAWN: CY				SHEET: 05 OF 12	A		
-		-	-	CHECKED: PZ				DATE: JUNE '19	A3		
A		FOR CONSTRUCTION	CY	17-6-19	SURF COAST SHIRE TORQUAY OFFICES 1 MERRIJIG DRIVE (P.O. BOX 350) TORQUAY, VICTORIA 3228 PH : (03) 5261 0600 FAX : (03) 5261 0526			PROJECT ENGINEER: CY			
No.	ZONE	REVISION	APPROVED	DATE				MANAGER ENGINEERING SERVICES: IS		STORM WATER PIT RAISE	

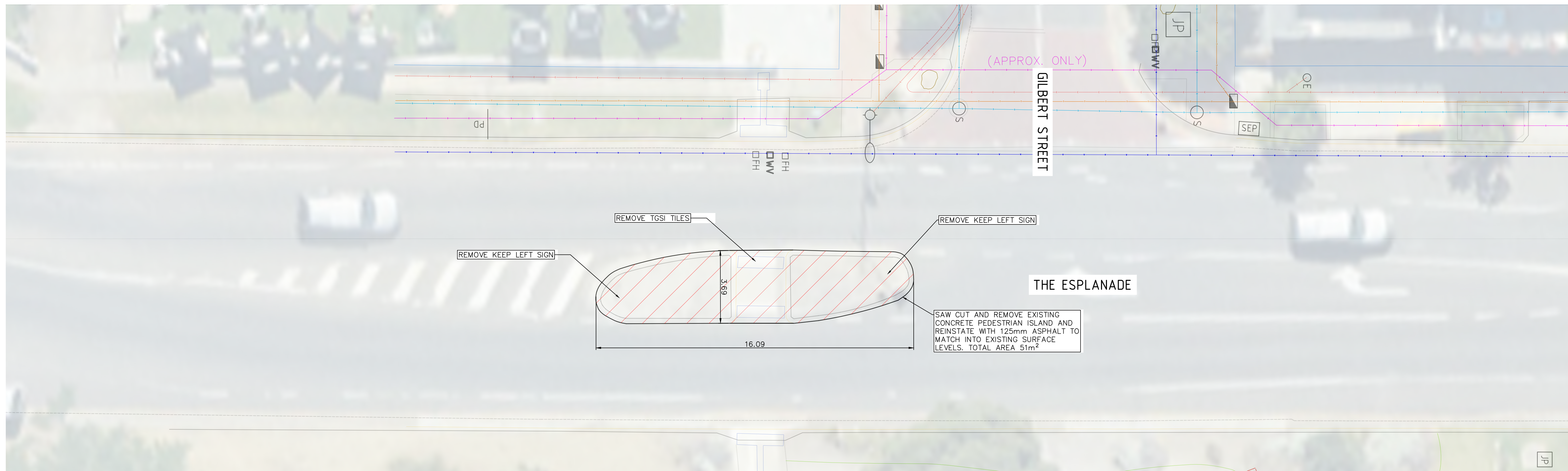

PAVEMENT DESIGN

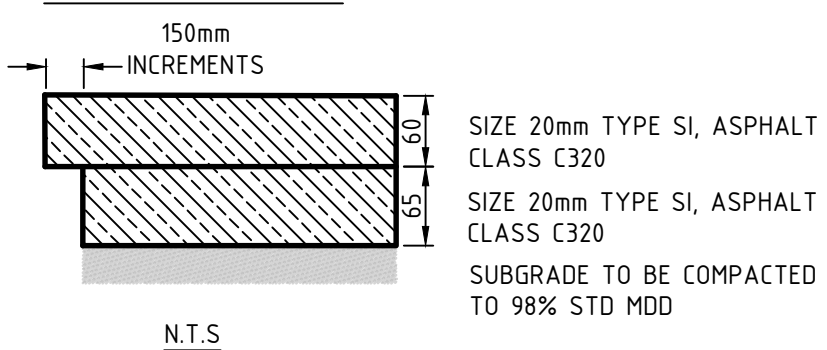

UNDERGROUND SERVICE LEGEND



NOTES

- ALL SERVICES TO REMAIN UNDISTURBED.

WARNING

BEWARE OF UNDERGROUND SERVICES AND OVERHEAD POWERLINES
THE LOCATION OF UNDERGROUND SERVICES SHOWN ARE APPROXIMATE ONLY AND THEIR EXACT POSITION MUST BE PROVEN ON SITE

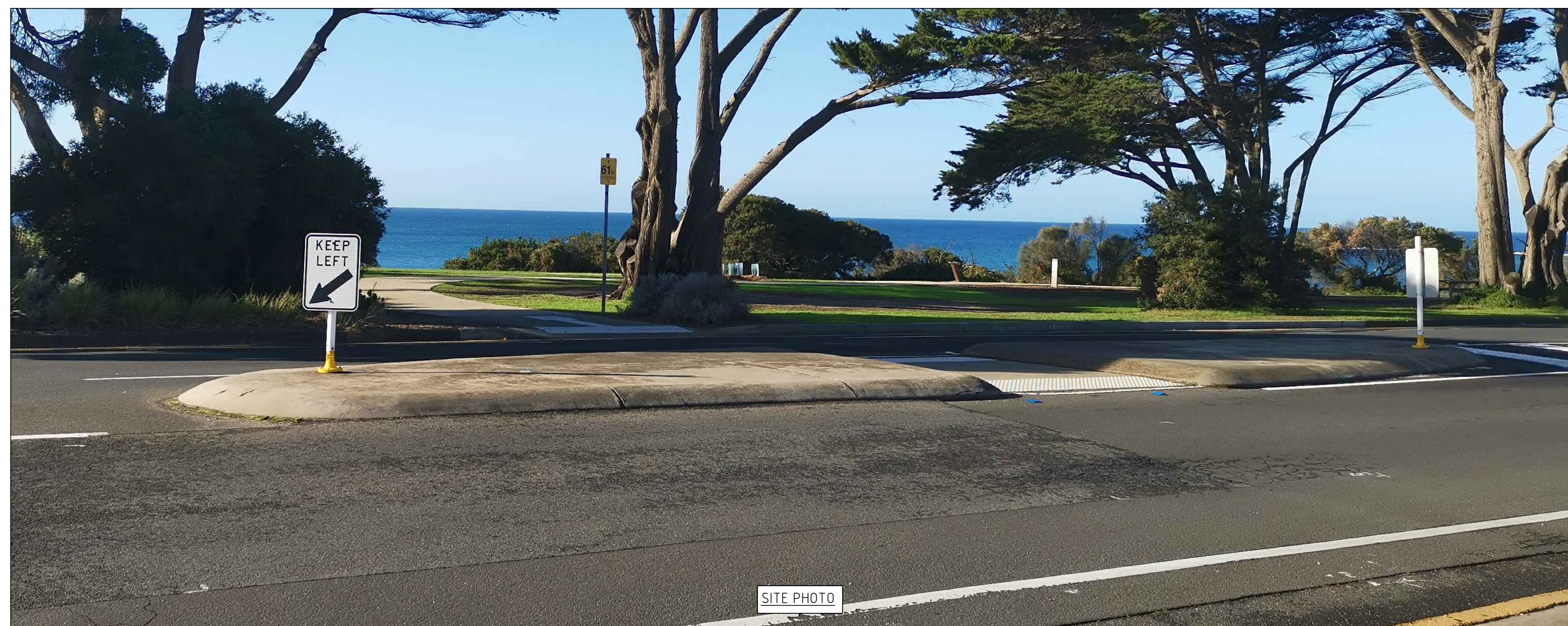

Rev.	Revision Details	By	Date	Approved
-	-	-	-	-
-	-	-	-	-
-	-	-	-	-
-	-	-	-	-
-	-	-	-	-
-	-	-	-	-
-	-	-	-	-
-	-	-	-	-
A	FOR QUOTE	CY	19-6-19	MG

© SURF COAST SHIRE
THIS DOCUMENT IS COPYRIGHT. NO PART OF IT CAN BE USED, AMENDED OR REPRODUCED BY ANY PROCESS, WITHOUT PERMISSION FROM THE INFRASTRUCTURE MANAGER OF THE SURF COAST SHIRE

SURF COAST SHIRE TORQUAY OFFICES
1 MERRIJIG DRIVE (P.O. BOX 350)
TORQUAY, VICTORIA 3228
PH : (03) 5261 0600 FAX : (03) 5261 0525

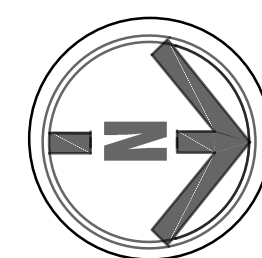

North Point

DESIGNED:	CY	DRAWING No.:	F18/668
DRAWN:	CY	SHEET:	
CHECKED:	AC	SCALE:	1:100 @ A1
PROJECT ENGINEER:	CY	DATE:	JUN '19
MANAGER ENGINEERING SERVICES:	IS		

THE ESPLANADE, TORQUAY
PEDESTRIAN IMPROVEMENTS
GILBERT STREET INTERSECTION

PEDESTRIAN ISLAND REMOVAL

REV.	A
	A3